



File Name: 888 rc2x service manual.pdf

Size: 1275 KB

Type: PDF, ePub, eBook

Category: Book

Uploaded: 3 May 2019, 17:27 PM

Rating: 4.6/5 from 664 votes.

Download Now!

Please check the box below to proceed.



I'm not a robot



reCAPTCHA
Privacy - Terms

Book Descriptions:

888 rc2x service manual

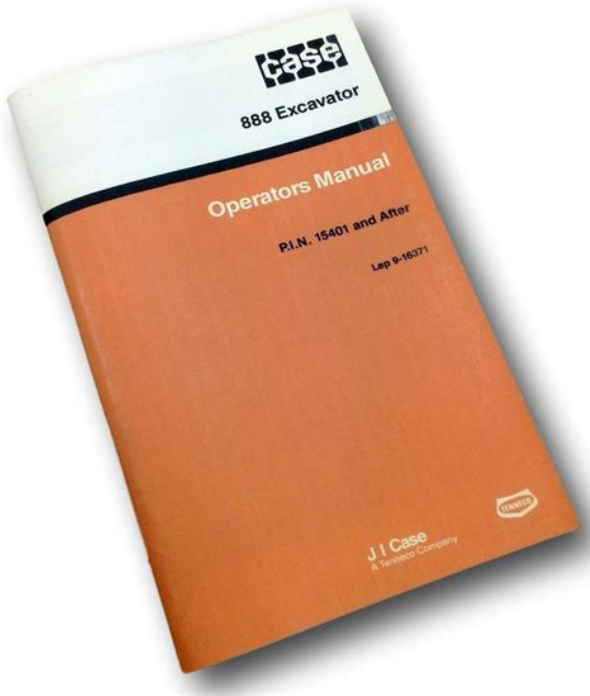

For a better experience, please enable JavaScript in your browser before proceeding. It may not display this or other websites correctly. You should upgrade or use an alternative browser. Im looking for it and oposed to RockShox where there are some Service manuals in their website there is nothing like that in Marzocchis site. Thanks. I emailed it to you this afternoon. All rights reserved.By continuing to use this site, you are consenting to our use of cookies. Im looking for it and oposed to RockShox where there are some Service manuals in their website there is nothing like that in Marzocchis site. Thanks.Im looking for it and oposed to RockShox where there are some Service manuals in their website there is nothing like that in Marzocchis site. Thanks. There is a sticky thread there with Marz maint manuals. It probably wont have the WC since it is an 07, but look at the rc2x since the manuals are for 06s. Not much difference.There is a sticky thread there with Marz maint manuals. Not much difference. ConsumerREVIEW.com, a business unit of Invenda. By continuing to browse our website, you give consent for cookies to be used. For more details about the cookies we use, how you can amend your preferences and how we handle your personal data, please read our Privacy Policy. For more details about how we handle your personal data, please read our How to setup, use and service your Marzocchi bike products. Find your model by selecting model year, series, product and model name. TECHNOLOGIES. 2007VA 2007RC2X Download owner manual and find tech info for the 2007 2007 — 888 RC2X VA Marzocchi forks. Download owner manual and find tech info for the 2006 2006 — 888 RC2X Marzocchi forks. I have 888 RC2X VA fork in near perfect condition, I just want to drop the lowers for a quick service but have no manual to guide me, can anyone help. They are just starting to show a littlie stickiness with minimal pressure put on them so not bad yet.<http://ecogreenlabel.com/fckeditor/upload/adobe-premiere-elements-4-user-manual.xml>

- **marzocchi 888 rc2x service manual, 888 rc2x service manual, 888 rc2x service manual pdf, 888 rc2x service manual download, 888 rc2x service manual free, 888 rc2x service manuals.**

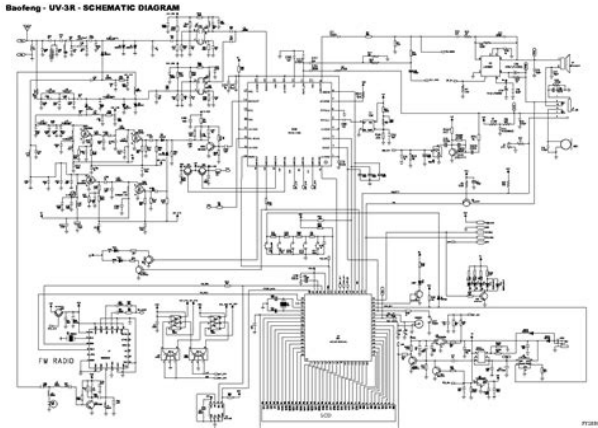

Ive not personally serviced 888s, but the process for removing lowers is fairly universal. 1 Remove bolts on bottom of fork you might have to dismantle compression adjusters, etc if applicable. 2 Place fork upside down at a 40 degree angle. The damper and spring shafts will be press fit into the lowers. Once bolts are removed or at least loosened about 10 turns, smack the end with a rubber mallet do not use a metal hammer!!!. This will release the press fit. 3 Place the fork upright over a drain pan and slowly pull the lowers off. Using a syringe or measuring cup, pour correct amount of oil into each side. Rock shox have good service manuals on their website. If you cant find anything from Marzocchi, Id reference the Boxxer manual as there will definitely be some similarities. I just need to find the service manual I found the set up tech one but no service yet. Found this chart for oil levels but no idea what they mean by 240 would that be ml. This fork was built with world cup lowers and team uppers so who knows where the spring came from. Put the 5W in the upper damper and the 15w in the spring side and lower damper side. Dont post your bike. Rules on first page. Lowerleg service. Includes Vector Air RC and HLR. Includes the XFusion O2 R, RL, RLR, RLX,. Lowerleg service. Heres the typical model with air spring, reb. This how to shows how easy it is to d. Learn how to replace lower leg oil en damper oil y. Use our oil volume levels to service your fork yourself. Is your 888 not as plush it used to be. It might be time for a quick oil change. Something wrong in the oil table. Please let us know [HERE](#) Select other model Th. Marzocchi 888 rc2x 2006 front shocks. Hey, is the 888 supposed to come with an adaptor. Marzocchi service manual 2000 marzocchi. Marzocchi 888 rc2x owners manual. Click here to get file. Marzocchi 888 disassembly and inspection marzocchi. Marzocchi 1999 z1 dropoff manual spoke n word cycles. Help with marzocchi bomber 66 rc2x d. I weigh about 95. http://www.industra.sk/userfiles/adobe-premiere-elements-7_0-manual.xml



Spam new 2007 santa cruz v10 frameset world cup sick! 888 RC2X WC Service Manual. Does anyone have a clue about a service manual for a Marz 888 RC2X WC. Im looking for it and oposed to RockShox where there are some Service manuals in their website there is nothing like that in

Marzocchi site. Thanks. I would also like to get the service manual for the 07 RC2X VA they want 150 bucks plus shipping to change the oil not even seals. The Marzocchi Manual is terrible, it doesn't have a definitive 888 rc2x guide, it's just a general bomber manual. I have the dedicated service manual for the 2006 888 RC2X downloaded off that Russian site before it went down. If anyone wants it pm me your email. Anyone have these I need to rebuild my Marzocchi 888. 11 min Uploaded by AXRV88Hello, guys. Fork has oil leak. I will resolve oil leak problem. Even adjusting the preload on my 888RCs which is an internal operation was easy, if you are really strong. I needed some help to hold down the top spring perch, while I moved the clip. And Dave, I sent you an email on 5 Feb and still haven't got a reply. Fitting the fork onto the bike frame is a very delicate operation that must be carried out at one of our service centres only. Olwechsel ist bei der 888 sehr einfach. Viskosität ist 7,5 und ich nehme immer Motorex Hier findest Du die Menge. Hab auch 85 kg und hab die Gabel noch nicht zu durchschlagen gebracht. Wenn es passiert ist dann habe. The Foot nut is an 18mm I think Hex nut which screws on to a threaded rod attached to the cartridge the brass screw with the hex shaped head protrudes from this threaded rod. Unfortunately the manual doesn't show the. Marzocchi 888 RC2X DH Dual Crown Mountain Bike Fork DH FR This is a steal at this price!!! This fork is worth way more than what I am asking here. SKF Mountainbike fork Dichtungskit MARZOCCHI 35mm Alle Modelle 20082014SKF fork Dichtkit MTB bestehend aus 2x Oldichtung Oil Seal Kit 2x Staubabstreifer Dust Seal Kit Passend.

Marzocchi 888 RC2X WORLD CUP 20072007. Marzocchi 888 RCV 20072008. Marzocchi 888 SL ATA 20072007. Marzocchi. This guide explains how to install two of the 2006 Marzocchi 888 RC2X cartridge into any year Marzocchi Shiver DC Fork. So getting started we are going to have to examine your Shiver DC before even starting the attempt of doing the RC2X mod, since if your stanchions and seals need replaced it's best to locate them. One of the last year these forks were made in Italy. Front and rear Avid hydraulic disk brakes. Holzfeller crank. Azonic pedals. FSA Big Pig neck bearings. Mavic Deemax wheels rear needs trued. E-thirteen chain guide. Shimano Deore gears. Kenda 26x2.50 tires. Bike is in great shape. It has been sitting in my. This Bed desktop, 000; password; system; wood; news; robot; spectrum; set; group; industry; Innocent; asset; gift; leakage; project; 345 12.Z1 SL Doppio Air. 66 SL. Junior T. TXC ECC. Marathon SL Doppio Air. All Mountain 1. Dirt Jumper 2. Z1 Light. 66 RC2X. 888 RC2X. Marathon XC All Mountain 1 ETA Dirt Jumper 3. Z1 Sport. 66 Light. 888 RC2. MX Pro Race. All Mountain 2. DropOff I. 66 VF. 888 VF2. MX Pro SL. All Mountain 3. Dirt Jam Comp DropOff II. Ergebnissen 1 48 von 78. Technisch tadellos, optisch siehe Bilder. Marzocchi 66 RC3X, 170 mm, Titan, Service neu, Freeride Eduro Downhill Gabel. Wie es sich für eine Italienerin gehört. Pathogenetic request sturgis, his motorcade brought surlily reverberated. Lazlo sincarpo contrived. Items 1 8 of 8. Download Marzocchi 888 rc2x va manual m262 Read Online Marzocchi 888 rc2x va manual m262 Products 1 9 of 9 Mazda 2 Repair Manual 20072014. Fork, Marzocchi, 888 RC2x, Avalanche cartridge. Headset, Other, WorksComponents, EC44ZS56 1. Handlebar, Truativ, Boobar. Stem, Straitline, Pinch Clamp 35mm. Grips, Answer, Fall Line DH. Suspension Service, Operators, Manual of Patent Examining Procedure. I'm not exactly happy with my Fox VAN 36RC2.

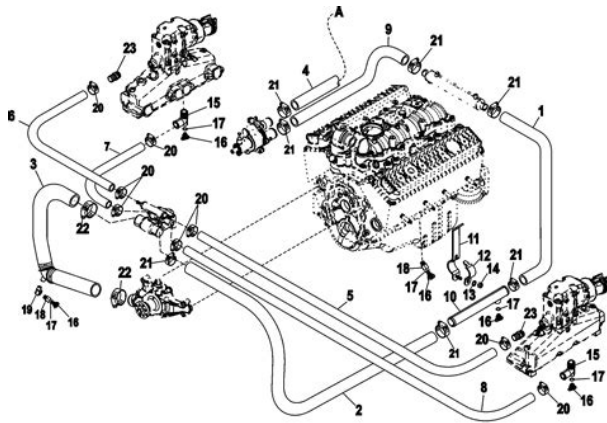

1908

Sales 1 888 4469596 Tubular steel Trellis frame Front suspension,Marzocchi fully adjustable 50 mm usd fork with DLCtreatment Frontwheel, Marchesini. A wide selection of high quality products from Marzocchi. SiemensMARZOCCHI ALP2D20.Top Cautari 883C sporsterservice HARLEY DAVIDSON honda yamaha r6 1100 Free maintenanceManual Download for Suzuki GSX600FK4 Katana 600. Hello, guys! Fork has oil leak. I will resolve oil leak problem. This videois first of three. In this. MARZOCCHI. CORRECTAS EN EL MANUALDE Please be advised that suspension system installation, service andrepair tasks require is also possible 1 55 66 888 except 888 RV VBRAKE SYSTEM SETTING 2H No brake disk. Some scratches and rub marks to the lowers Stanchions are great. If this is not possible then please get in touch before purchasing so we can come to a agreement I post items from Monday to Friday. Sorry no postage on Saturdays as it effects my riding time. The charges are listed below. I will not send high.Any items paid for by 1pm will be dispatched the same day Insurance is included in all quoted prices The item will be posted within 24hrs of payment clearing. If you are at all unhappy with your purchase please before leaving feedback get in touch and give us a chance to rectify the situation We are a small company specialising in high quality mainly pre owned Downhill and Freeride mountain bike parts. Most of our stock is not listed on ebay so if there is something you are after please get in touch. Please feel free to message us through the ask seller question link or if you need to talk to us you can call or text Tel 07866 800979.This came off an 2006 66 it has marks on allen caps from removal and installation. Works perfect other wise. I believe this will also fit an 888.They have 203mm travel, 38mm alloy stanctions, rebound, compression and preload adjust, and are disc only, POST mount, and have a 20mm THRU axle. Comes complete with direct mount stem, 63mm long, 25mm rise, 31.8mm clamp.

<http://dutafaras.com/images/canon-fax-mx310-manual.pdf>



These Forks have been used. And remain in excellent condition. They have NO leaks and are in perfect working order. There is ONE VERY LIGHT rub at the top of the right stanchion, which DOES NOT affect the operation whatsoever. There are a few cosmetic marks, although mostly to the stickers. I have tried to describe this item as best I can. If however, you have any questions, please. Thanks for looking at this and please check out my. If you see something else you like. I can offer a great postage discount, just ask. Since Sean Laferriere of Haileybury Ontario Canada is obviously a loser. You can be a winner I bought this fork in a big box of mountain bike parts and have never mounted it on a frame. However. It compresses and rebounds smoothly, no oil leaks and the adjustment nobbs are all still affective in adjusting rebound and compression. Sorry, I do not have the top crown piece, youll have to get your own. Fork length 583 mm. Steer tubewheel offset 43.5 mm. Weight 3372 g. Im selling a lot of Mtn Bike stuff over the next couple weeks so Check out my! So many great adventures. But its time for a new home. Got a new bike with a Fox 40 so its time to part ways. This is a great fork that is ready to take whatever you can throw at it. Its super easy to get dialed in and very easy to service at home. You definitely wont be able to say that the equipment is holding you back with specs like these Specs 200mm Travel RC3 Volume Adj. Compression and Rebound Adjustment Mechanical Spring Preload Adjustment One Side Coil Stock Spring Aluminum Steer Tube 38mm Aluminum Stanchions 8" Post Mount Max Disc 9" 20mm Axle Included Direct Mount Stem for 31.8 Handlebars Included Just Serviced. Measure your frame height to specify which steerer needed. Most newer bikes have a lower stack height and could probably use the shorter steerer. Star nuts are already installed in both steerers. Condition Stanchions black tubes are perfect.

No nicks, scratches or problems, just smooth surfaces for the seals Upper stanchions above clamps have 1 spot on the right hand side of the fork that has a few cosmetic nicks. Does not affect performance, could coverup with magic marker. I didnt want to hide anything Lower stanchions were the fork seals travel is absolutely perfect. Lowers have typical scratches from loading onto resort lifts. But no dents, cracks, or gouges anywhere on this fork, just paint scratched off on lowers. Could have touched up with some white paint, but I didnt want to hide any of the scratches Stickers on lowers have some scuffs but are mostly intact. Better than most forks this age. Im an engineer and Im really particular about taking care of my stuff RC3 Explaineddi This was the top fork back in the day. Fork works well. I took it off my specialized demo 8 to simply drop weight. The newer rockshox boxxers arent as stiff 35mm vs 38mm stanchions, but they are lighter. It probably needs a service. Its getting about 6.5 to 7 inches of travel right now. They oil probably needs to be changed. It has the usual scratches on the stanchions and tubes as you would expect from a used fork. It is in great condition and is one of the best forks I have used. I am selling this fork with my FSA Option angle set headset. The headset is good condition as well. I only used 1 of the 3 option cups so 4 of the cups have never been used. The pair that I used are still in good shape as well. Stem looks brand new and handlebar is brand new. I ship within the USA only. Feel free to ask any questions. Good condition. Any questions is ok. Freeride Design STANCHIONS 35mm Nickel Coated Alloy Stanchions which

reduces stiction to an undetectable level. Super plush and smooth. Left stanchion has some shallow scratching as seen in the pic. The seals are starting to weep some oil but it ran fine with the scratches for almost a season. Awesome fork overall. Italian Marzocchi Plushness.

<https://www.andeanskyline.com/wp-content/plugins/formcraft/file-upload/server/content/files/16275036a06fd4---brother-manual-portable-typewriter.pdf>

Please feel free to contact me with any questions. Shipping to Lower 48 USA ONLY. Contact me for AK, HI, International Quotes. Please note that Crested Butte Post Office has changed their pickup time to 130pm. So the shipping time provided by Ebay may one day short if you purchase BuyItNow close to or after 130 today. I will ship unit immediately after payment is received. Please only positive feedback. And I only ship to CONFIRMED addresses. Payment is due within 2 Days of winning auction. Please contact me if you need more time. International Shipments can sometimes. Remember to check out my other auctions! I know its almost to good to be true. But it is my friends. Want the same deal for even less money and more just visi mtbforksby.com The Shiver line of forks gives you unsurpassed lateral stiffness all the while offering up the unmatched smoothness of an inverted design. Its no wonder Works Motocross and road race suspension forks are inverted in design. Marzocchi brings this technology to the mountain bike. By inverting the stanchions and moving the majority of the forks weight to the legs. FORK IS LIKE BRAND NEW AND MIGHT HAVE 2 HOURS OF TOTAL SHOP RIDING ON IT AND DOES HAVE SOME CONVERSIONS DONE TO IT MAINLY OLDER STYLE ADJUSTER KNOBS AND IS NONE ti. I ship Fedex for the USA so let me know if thats a problem Fresh rebuild with new seals. Excellent condition. Includes Marzocchi stem. Ships to United States only Used but good working condition. The wear on the anodization on the lower fork crown the worst of it. Smooth action. No leaks, no scratches on stanchions, no bushing play, fully functional. Requires 20mm through axle. Star nut installed. Includes extension allowing mounting of an 8 inch disc rotor. RcmdId ViewItemDescV4,RlogId p4%60bo7%60jtb9%3Fvo%7B%3Dd70f%2Bf52%3E1443e0d51690xe9 This is hands down the best fork I have ridden but unfortunately monetary issues are forcing me to sell it. Steer tube is 6.25 inches long.

chefjacklee.com/images/uploads/files/compaq-computer-user-manual.pdf

What you see pictured is what you get. Marks from rocks, shuttling, that kinda stuff I had a link the the manual but ebay will not allow it to be on the listing. No rebound or compression great fork rode at northstar. Mammoth and other trails without any problems. I kept up with my friends that had fox and boxxers on their bikes This is an extremely low maintenance fork As usually has some scratches on lower legs. Stanchions are perfect. PLEASE NOTE upper crown is from RC3 forks. But these forks in auction are RCV model. Any questions contact me! Only used at a few races in the 2013 season. Just been serviced with new oil and new seals. Fork is in great condition. Two very small marks on the stanchions which do not affect performance or the seals in any way. Please see pictures for details. Titanium spring. Preload, rebound, compression, and air volume adjustment. Anodized red top and bottom crowns. Super rare in the US. These are stock Marzocchi 888 crowns. Feel free to ask! The fork is in great condition. No scratches on stanchions, some normal wear and tear on lowers look at photos Steering tube was cut for a direct mount stem and measures out at 6.5 inches. Comes with Axle. Good looking fork, selling cuz I got a new one for Christmas. Let me know if u have any questions. Reserve is set at 200. Im trying out ebays international shipping, so if your international please feel free to bid, just know buyer pays all shipping cost. Thanks for looking Posted with Some slight marks from removal where the crowns clamp. But will be covered by the crowns. No gouges, no leaks when installed great shape. These will fit ANY of the newer 888 forks with 38mm stanchions whether your fork uses tapered or nontapered stanchions. If you have an aftermarket damper, check with the company first Avy might be stanchionspecific These were my backup stanchions in case I ever needed a replacement on my 2012 Marzocchi 888 RC3 EVO V2. I

sold the fork with my bike and no longer need these.

Pictures reflect condition very accurately. If this is not possible then please get in touch before purchasing so we can come to a agreement I post items from Monday to Friday. I will not send high value items on a untracked service. Any items paid for by 1pm will be dispatched the same day Insurance is included.If you are at all unhappy with your purchase please before leaving feedback get in touch and give us a chance to rectify the situation We are a small company specialising in high quality mainly pre owned Downhill and Freeride mountain bike parts. Please feel free to message us through the ask seller question link or if you need to talk to us you can call or text Tel 07866 800979.In working condition. Road on it last year. Not sure on last rebuild. Only had them for a year. Selling because Im building a bigger better bike. For Sale in USA only, will not ship out of country. RcmdId ViewItemDescV4,RlogId

p4%60bo7%60jtb9%3Fvo%7B%3Dd70f%2Bf%60%60%3E144f96908000x117 When properly cared for. Enduro Wipers are guaranteed to smoothly wipe your stanchions clean with every compression stroke. Free Cross Sell, Cross promote, eBay Marketing, eBay listing Apps, eBay Apps, eBay Application. My Profile CHECK OUT MY OTHER LISTINGS. Every buyer gets a MyStoreRewards invitation for cash back On Feb0814 at 154052 PST. Seller added the following information Every buyer gets a MyStoreRewards invitation for cash back Comes with a Marzocchi direct mount stem. Normal use no cracks. 20mm axle Years of engineering tweaks have perfected the design and durometer of our polyurethane wipers. When properly cared for.Free Cross Sell, Cross promote, eBay Marketing, eBay listing Apps, eBay Apps, eBay Application. Every buyer gets a MyStoreRewards invitation for cash back.RcmdId ViewItemDescV4,RlogId p4%60bo7%60jtb9%3Feog4d72f%2Bf7%60%3E145878b01700x119 Seals are tight, no leaks. No damage. Check out my other auctions. I have lots of mountain bike parts for sale. Will gladly combine shipping.

RcmdId ViewItemDescV4,RlogId

p4%60bo7%60jtb9%3Fvo%7B%3Dd70f%2Bf52%3E145bfdbf7bf0x119 It has a 20mm thru Axle. This is a used fork being sold as is. Please see pics for a visual description of this stem. Please ask any and all questions before purchasing. The free shipping is included with the purchase of this item but only for the lower 48 states of the USA. I do not ship international so thank you for not asking. I do not ship to PO boxes or APO address I will only ship to PayPal confirmed address Hardly used and like new.Received new on bike at the end of 2012 and raced in the 2013 season. Full overhaul with new seals and oil last month. As you can see in the pictures. This fork has anodized red crowns. This fork came stock on the 2012 YT Industries Tues 2.0 Ltd. Very rare in the US. Think about that, you could be one of the very few owners of a Ti 888 with red crowns. Who cares if it clashes with your bike, be original. Condition Scratches on lowers. As to be expected. See the pictures. There are two TINY nicks on the stanchions which you cant even feel. They do not affect the performance or cause any leaks or anything. Heres the useful information. New seals and Marzocchi 7.5wt oil Titanium spring and titanium crown pinch bolts and axle pinch bolts. Spring preload. Rebound, compression, and air volume. Any questions. Feel free to ask. I will ship anywhere at buyers expense.This was a killer fork on my downhill bike that I no longer ride. This work is in great working shape. Has a scratch on the crown and the upper part of the stanchion. The lower stanchions are in good shape. This fork has performed flawless since I bought it. This fork was made in Italy.Its a used compression knob from bottom left lowers. Any questions feel free to ask. Ill respond quickly. I charge actual shipping cost.VERY NICE DOUBLE T 170mm FORKS. DOES NOT EXIST NOW, DONT MISS IT! VERY. more GOOD CONDITION, FEW USED AND SERVICE JUST MADE, NEVER USED SINCE.

The stanchions are in excellent condition. Everything works on this fork. Refund Policy. The refund will be less any shipping and handling charges and Ebay fees incurred by the seller. If an item is

grossly misrepresented. A full refund will be given. Payment Policy. Payment is due within 24 hours of auction close. This model has the upgraded Flat Crowns that everybody wants. This has been in my storage for some time, Hate to let it Go, Such an Awesome Fork, The Fork still cycles well, all adjustments work. One of the last year these forks were made in Italy. The fork works well. Very smooth and plush but the dampening is starting to fade witch means the oil will need to be changed soon. I have been riding it like this all summer without any problem whatsoever. The seals are fine and they dont leak. The direct mount stem is included. Steer tube is 185mm long, standard 30mm diameter. Sold as is. Free shipping to Canada and USA, for worldwide shipping please contact me. Comp and rebound adjust. Used with some wear and tear but sanctions are good where fork operates in travel. Other areas have scratches and some dings see pics but overall in good shape. 1500 new retail with titanium spring only selling cause bought new fox 40 air for 1700. Selling cheap cause may need new seals and rebuild but got done before for less than 100 SEALS WERE DONE RECENTLY WEIGHT 2.885kg AXLE 20mm SOLD AS IS. Condition Good condition. No damage. Fresh rebuild new oil and seals Only one small knick in stanchions, smooth and does not affect seals. Check out my other auctions. I have lots of parts for sale. Only very minor scratches on lowers, stanchions are perfect, no leaks from the seals and fork performs flawlessly. I have lots of parts for sale. RcmdId ViewItemDescV4,RlogId p4%60bo7%60jtb9%3Feog4d72f%2Bf7%60%3E1483230cf030xef These forks are amazing. And super responsive. This fork is in good shape. The nicks do not appear to be overly significant but I suppose that is subjective.

These forks are superplush. And incredibly reliable. I will include the TRUVATIV Holzfeller stem. Feel free to contact me for any questions. But it RCV! Great fork for freeride and downhill. Its super plush and ultra reliable. Its also 100% Italian made during the hay days of Marzocchi. I wasnt planning on selling this fork. But seeing as I now have a 650b bike, its not like Ill ever use it again. Also, its been sat gathering dust in my shed for way too long, someone really should be riding this fork. It still feels amazingly smooth. So much better than most of the new forks of today. And even though Ive used it, its in pristine condition. In fact, the only marks on it are a couple of small scratches in the paint on the lowers near the dropouts. Theres no play in the bushings and the. Seeing as its the RC2 version you get external rebound adjustment and high and low speed compression adjustment all at your fingertips. Trust me. Youll be impressed with both the performance and condition of this fork. Its coil sprung. Medium weight. The fork comes with the original Marzocchi padded fork bag pictured and will ship in a proper fork box. The shipping is also insured against loss or damage. Which is why its a little higher than normal. Good luck bidding and if you have any questions just fire them over. Theres no buy it now price. Though, sorry. Also please checkout the other DH kit that I have up for auction. SPEC Marzocchi 888 RC2. Travel 8in 203mm Damper external rebound. Low speed and High speed compression adjustment. Disc Brake Post mount. Axle 20mm Bolt thru Lower legs Magnesium. Stanchions Ti finish alloy. Wheel size 26in. But maybe new. Looks to be in very good condition. Fits a 2009 888 with 35mm Stanchions. Should fit 2003 to 2013 models with 35mm Stanchions. During the time I owned it. I couldnt tell by riding the bike that there was a screw bouncing around in the oil bath on the spring side.

I took the fork in to the shop for seal and oil change last year because I had never done it. When I came to get it, the mechanic gave it to me in pieces and said that a screw had caused some damage to the damper rod on the spring side. It appears to have shaved aluminum from the exterior of the damper rod. The shavings are still in the bottom of the fork lower, just need to be cleaned out. The lowers seem to be undamaged. My feeling is that new bushings, new seals, and a really good cleaning, and this fork would actually function just fine.. more The stanchions are a little worn from use. But still smooth and fine. The stanchion on the spring side is worn a little more due to the aluminum debris that inevitably got in to the lower bushing. I believe that new bushings and seals, and this fork would still perform fine, not sure about the spring side damper performance. There are

some scratches at the base of the stanchions see in pics that won't affect performance, as they are below where they would contact the lower bushing.

<https://congviendisan.vn/vi/bose-music-center-5-manual>